

19 mm Dome Tweeter

D2010/851300

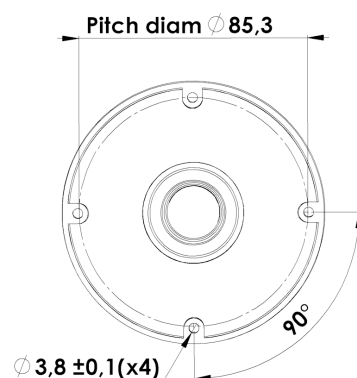
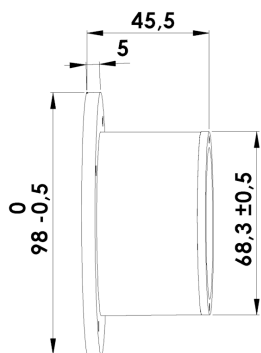

Key Features:

- 3/4" Textile Dome Diaphragm
- Wide Dispersion
- Diffraction Damping Foam Front
- Dual Rear Chamber
- Ferro Fluid

Recommendations (please see Tech Note):

- Operating frequency range: 4000-20000 Hz
- Cabinet volume - closed box: N.a.
- Cabinet volume - vented box: N.a.

T-S Parameters:

Resonance frequency [fs]	800 Hz
Mechanical Q factor [Qms]	1.26
Electrical Q factor [Qes]	1.24
Total Q factor [Qts]	0.63
Force factor [Bl]	2.4 Tm
Mechanical resistance [Rms]	1.00 kg/s
Moving mass [Mms]	0.25 g
Compliance [Cms]	0.16 mm/N
Effective diaph. diameter [D]	22 mm
Effective piston area [Sd]	3.8 cm ²
Equivalent volume [Vas]	0.01 l
Sensitivity (2,83V/1m)	88 dB

Mechanical Data:

Voice coil diameter	19.4 mm
Voice coil height	2.9 mm
Voice coil layers	2
Gap height	1.9 mm
Linear excursion	± 0.5 mm
Max mech. excursion	± 1.2 mm
Unit weight	0.4 kg
Cabinet Displacement Volume	0.14 l

Electrical Data:

Nominal impedance [Zn]	8 Ω
Minimum impedance [Zmin]	6.4 Ω
Maximum impedance [Zo]	11.5 Ω
DC resistance [Re]	5.7 Ω
Voice coil inductance [Le]	0.08 mH

Power Handling:

100h RMS noise test (IEC 18.4)	90 W
Long-term max power (IEC 18.2)	150 W
X-over: 2. order HP Butterworth, 4 kHz	

